

MOTOR SPECIFICATION SHEET

MODEL : SF-QR 7.5HP 2P (HT)

USED FOR : STANDARD

DESCRIPTION	DETAIL		
PHASE	3		
MODEL NAME	SF-QR		
RATED OUTPUT, HP (kW)	7.5 (5.5)		
POLE	2		
CODE	MEATH CODE : 1M002F-200550QRMJ0		
OUTLINE DRAWING NO.	ONM24O161-C		
RATED VOLTAGE (V)	380	415	
RATED FREQUENCY (Hz)	50	50	
RATED CURRENT (A)	11.4	11.2	
RATED SPEED (min ⁻¹)	2900	2910	
RATED EFFICIENCY (%)	84.7	84.7	
EFFICIENCY CLASS	IE1		
THERMAL CLASS	155(F)		
RATING	S1 (CONTINUOUS)		
ENCLOSURE CONSTRUCTION	TOTALLY ENCLOSED FAN COOLED		
DEGREES OF PROTECTION	IP55		
METHOD OF COOLING	IC411		
FRAME NO.	132S		
WEIGHT (kg)	43		
STANDARD	IEC 60034-1, IEC 60034-30-1		
INSTALLATION	FOOT MOUNTED		
ROTATION	CCW (VIEWED FROM SHAFT END)		
BEARING	LOAD SIDE	: 6308ZZ	
	OPPOSITE SIDE	: 6207ZZ	
BEARING GREASE	UREA GREASE		
NOISE (dB.A)	83		
VIBRATION	V10		
CIRCUMSTANCE CONDITION	AMBIENT TEMPERATURE	: -20 ~ +40°C	
	AMBIENT HUMIDITY	: 95%RH OR LESS	
	ABOVE SEA LEVEL	: 1000m OR LESS	
	ENVIRONMENT	: NO BURSTING/EROSIVE GAS OR VAPOR	
COLOR	MUNSELL N1.5 (BLACK)		
TERMINAL BOX	NO. OF LEAD WIRES	: 6	
	SOURCE CONNECTION	: TERMINAL BLOCK	
SHAFT SWING	≤0.03mm		
MATERIAL	FRAME	: STEEL PLATE	
	BRACKET	: ALUMINIUM	
	SHAFT	: CARBON STEEL	
	STATOR CORE	: ELECTRICAL STEEL	
	WIRE	: ENAMELLED COPPER MAGNET WIRE	
	ROTOR CORE	: ELECTRICAL STEEL	
	CONDUCTOR	: ALUMINIUM	
	TERMINAL BOX	: STEEL PLATE	
PAINTING	: POLYURETHANE RESIN		
PRODUCTION COUNTRY	THAILAND		

Specifications subject to change without notice.

SPECIFICATION SHEET NO.				
SS-M-2992-A				

MODEL SF-QR THREE PHASE INDUCTION MOTOR OUTLINE DRAWING

TOTALLY ENCLOSED FAN COOLED TYPE
 DEGREES OF PROTECTION IP55
 DUST & WATER JET PROOF

CUSTOMER _____
 USER _____
 FOR _____
 CUSTOMER'S ORDER NO. _____
 QUANTITY _____
 MFG. ORDER NO. _____

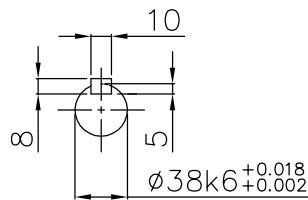
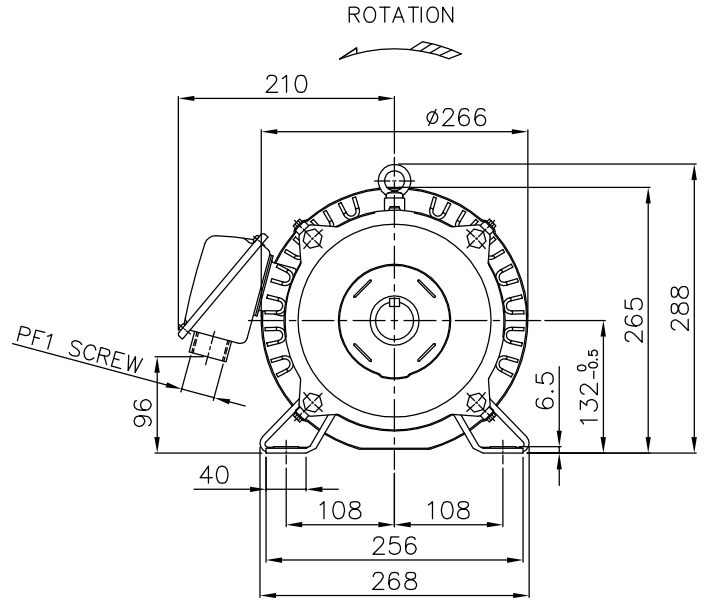
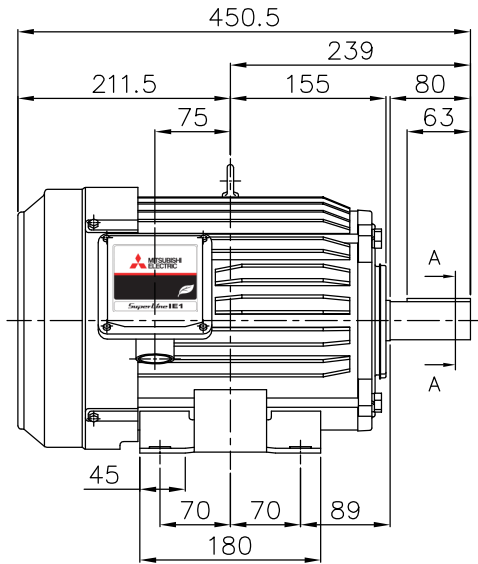

SECTION A-A

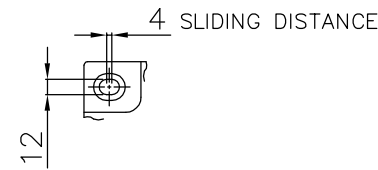

FRAME FOOT AS VIEWED FROM BELOW

YOUR ORDER	FRAME SIZE	RATING	TH. CLASS	AMB. TEMP.	BEARINGS		COLOR	DIRECTION OF ROTATION (VIEWED FROM SHAFT END)	NO. OF LEAD WIRES	REMARKS
					LOAD SIDE	OPP. SIDE				
	132S	S1 (CONT.)	155(F)	40°C	6308ZZ	6207ZZ	BLACK (MUNSELL N1.5)	CCW	6	

YOUR ORDER	OUTPUT		POLES	VOLTS	HERTZ	AMP.	RPM	IE CODE-RATED EFF.	REMARKS
	HP	KW							
	7.5	5.5	2	220/380/415	50	19.7/11.4/11.3	2885/2885/2910	IE1 84.7%/84.7%/84.7%	LT
	10	7.5	2	220/380/415	50	25.5/14.7/14.0	2890/2890/2910	IE1 86.0%/86.0%/86.0%	LT
	7.5	5.5	4	220/380/415	50	20.2/11.7/11.6	1450/1450/1460	IE1 84.7%/84.7%/84.7%	LT
	5	3.7	6	220/380/415	50	14.5/8.4/8.3	950/950/960	IE1 81.8%/81.8%/81.5%	LT
	7.5	5.5	2	380/415	50	11.4/11.2	2900/2910	IE1 84.7%/84.7%	HT
	10	7.5	2	380/415	50	14.8/14.2	2900/2920	IE1 86.0%/86.0%	HT
	7.5	5.5	4	380/415	50	11.7/11.7	1450/1460	IE1 85.8%/85.6%	HT
	5	3.7	6	380/415	50	8.52/8.50	950/960	IE1 81.8%/81.5%	HT

MITSUBISHI ELECTRIC AUTOMATION (THAILAND) CO., LTD.

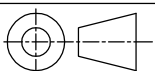

DIMENSION IN mm.
 SCALE : NTS

OUTLINE DRAWING NO.

REV.

0 N M 2 4 0 1 6 1 C